

ML4064-MCB-112

Technical Reference

MSA Compliant OSFP MCB

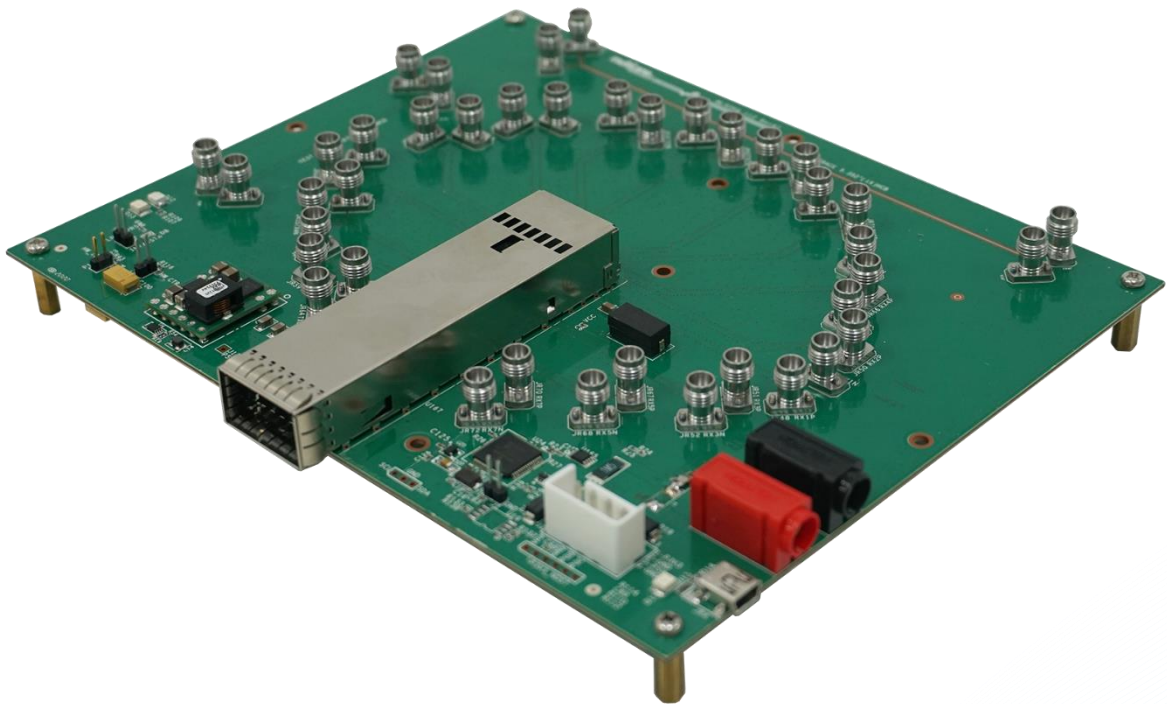

Table of Contents

1. Introduction	3
2. Key Features	3
3. Ordering options	3
4. ML4064-MCB-112 Hardware	4
4.1 Power-Up	4
4.2 Operating Conditions	4
4.3 LED Indicators	4
4.4 Low Speed Signals	5
4.4.1 External I2C	5
4.4.2 External HW Control	5
5. ML4064-MCB-112 Software	6
5.1 USB Driver	6
5.2 GUI	6
6. Hardware Revision	6
7. Firmware Revision	6
8. Bootloader	7

Table of Figures

Figure 1: External I2C	5
Figure 2: External Control Signals	5
Figure 3: Low Speed Signals Schematics	5

1. Introduction

The ML4064-MCB-112 is designed to provide an efficient and easy method of programming and testing 800G OSFP transceivers and active optical cables. It includes a complete user-friendly GUI supporting all features defined by OSFP MSA and simplifying configuration processes to enable intuitive memory map programming and testing. It is designed to simulate an ideal environment for OSFP transceivers module testing, characterization and manufacturing.

2. Key Features

- ✓ Supports 8x112G interfaces
- ✓ I2C master driven from both on board microcontroller or external pin headers
- ✓ 2.4mm or 1.85mm Connectors
- ✓ Current Sense
- ✓ Matched differential trace length across all channels
- ✓ High performance signal integrity traces from K connectors to OSFP host connector.
- ✓ On-board pin headers for MSA input control signals
- ✓ User friendly GUI for I2C R/W commands and loading custom MSA memory maps
- ✓ Four corner testing capability
- ✓ USB interface

3. Ordering options

Option	Part Number	Description
#1 – IHS	ML4064-MCB-112	OSFP MCB with regular OSFP IHS cage
#2 – RHS	ML4064-MCB-112-RHS	OSFP MCB with OSFP RHS cage



ML4064-MCB-112

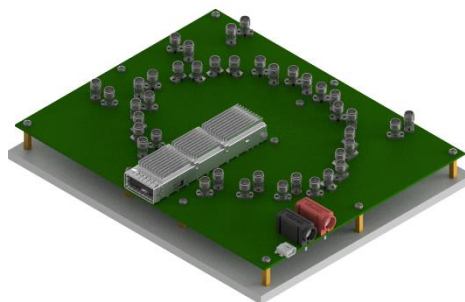

ML4064-MCB-112-RHS

4. ML4064-MCB-112 Hardware

The subsequent sections cover the essential parts in the hardware, for board operation and testing.

4.1 Power-Up

To power up the ML4064-MCB-112 host, steps are as follow:

- The host TOP is where the cage is mounted
- Two options are available to power up the board:
 - Using the four pins power connector (J2) that should be connected to 5V AND 3.3V taking into account pins distribution, where jumper U2 must be populated
 - Using the banana plug (U8) that should be connected to 3.3V where jumper U1 must be populated
- Connect the host to your PC using a Type-B mini to Type-A USB cable.

4.2 Operating Conditions

According to the powering method described in section 3.1, the input voltage supply must follow the table below.

Parameter	Symbol	Condition	Min	Typical	Max	Unit
+5	P5V	Supply from J2 (P5V pin)	-	5	-	V
+3.3	P3V3	Supply from J2 (P3V3 Pin) OR banana plug U8	3.0	3.3	3.6	

Table 1: Voltage Operating Conditions

4.3 LED Indicators

The ML4064-MCB-112 includes on-board LEDs, for quick debugging and monitoring purposes. LEDs are summarized below:

- LED D11 indicates whether a USB cable is plugged or not.
- LEDs D13 and D12, colored green and red, respectively, are used for diagnostic purposes:
 - ✓ If D13 is on: USB is locked and device is recognized by the USB driver
 - ✓ If D12 is on: USB is not connected or USB driver is not found
 - ✓ If both are off: board is not powered correctly or firmware is corrupted
 - ✓ If both are blinking: the board is in Bootloader mode

4.4 Low Speed Signals

4.4.1 External I2C

The I2C bus can be accessed externally using U156 pins. In this case a jumper should be placed on pin header P16 (HW_I2C) shown in the image below.



Figure 1: External I2C

4.4.2 External HW Control

Also Low Speed Signals are controllable using an external source, this can be done through J4 pin header. In this case a jumper should be placed on pin header J3 (HW_CTRL) shown in the image below.

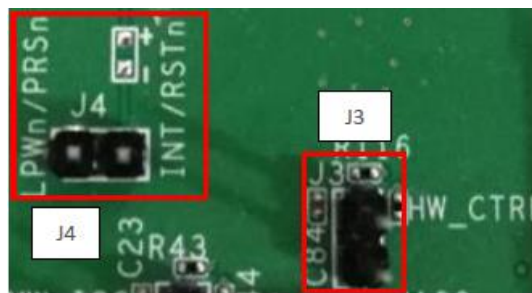

Figure 2: External Control Signals

The low speed signals circuit shown below shows the connection of these signals to the microcontroller and OSFP connector.

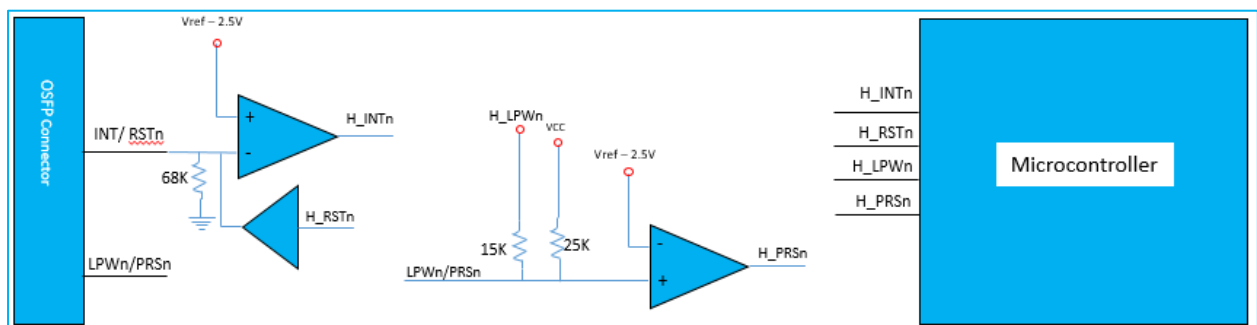

Figure 3: Low Speed Signals Schematics

5. ML4064-MCB-112 Software

The ML4064-MCB-112 is accessible and controlled through application software. This software is MSA compliant and provides a user-friendly interface to operate the board and access all its features. The communication between the ML4064-MCB-112 board and the software is established through USB connection.

5.1 USB Driver

In order to be able to communicate with the board, user need to install the USB driver of the ML4064-MCB-112. This is available on the website under the following link (USB Driver icon):

<https://www.multilaneinc.com/product.php?pn=ML4064-MCB-112>

Below is a brief guide on how to install the USB Driver:

- Power up the board
- Connect the board to the PC through USB cable
- Download the USB driver file
- Go to “Device Manager”
- Find the target device that need to install the driver
- Right-click on the device and select Update Driver Software
- Select Browse my computer for driver software
- Browse you PC and select the driver file
- Click Next and wait until the driver is installed

5.2 GUI

For GUI installation and operation, refer to the link below. GUI user manual is available for detailed description (CMIS GUI Manual icon).

<https://www.multilaneinc.com/product.php?pn=ML4064-MCB-112>

6. Hardware Revision

- **ML4064-MCB-112_RevA1:** Initial Version

7. Firmware Revision

- **ML4064-MCB_V1_4:** latest FW revision, compatible with the ML4064-MCB-112 RevA1 hardware.

8. Bootloader

Accessing in bootloader mode allows the user to reprogram the microcontroller, this is done as described below:

1. Connect a jumper on (J1) situated close to the microcontroller.
2. Connect a USB cable between the PC and Board.
3. Power up the board with a +3.3V supply.
4. LEDs (D12, D13) start blinking.
5. Remove jumper.
6. Open the software "Microchip USB HID Bootloader v2.3".
7. Click on "Open Hex File".
8. Choose the new FW to download.
9. Click on "Program/Verify".
10. Once the software finishes programming press on "Reset Device".
11. After reset the Firmware is successfully updated.

Revision History

Date	Revision	Description
8/14/2024	0.1	<ul style="list-style-type: none">Initial Version
8/20/2024	0.2	<ul style="list-style-type: none">Updated Section 2
10/28/2024	0.3	<ul style="list-style-type: none">Added section 3

North America

48521 Warm Springs Blvd. Suite 310
Fremont, CA 94539
USA
+1 510 573 6388

Worldwide

Houmal Technology Park
Askarieh Main Road
Houmal, Lebanon
+961 5 941 668

Asia

14F-5/ Rm.5, 14F., No 295
Sec.2, Guangfu Rd. East Dist.,
Hsinchu City 300, Taiwan (R.O.C)
+886 3 5744 591